



EN

Welding machine

Picomig 220 puls TKG

Picomig 220 Synergic TKG

099-005680-EW501

Observe additional system documents!

09.10.2024

**Register now
and benefit!
Jetzt Registrieren
und Profitieren!**

www.ewm-group.com



General instructions

WARNING



Read the operating instructions!

The operating instructions provide an introduction to the safe use of the products.

- Read and observe the operating instructions for all system components, especially the safety instructions and warning notices!
- Observe the accident prevention regulations and any regional regulations!
- The operating instructions must be kept at the location where the machine is operated.
- Safety and warning labels on the machine indicate any possible risks. Keep these labels clean and legible at all times.
- The machine has been constructed to state-of-the-art standards in line with any applicable regulations and industrial standards. Only trained personnel may operate, service and repair the machine.
- Technical changes due to further development in machine technology may lead to a differing welding behaviour.

In the event of queries on installation, commissioning, operation or special conditions at the installation site, or on usage, please contact your sales partner or our customer service department on +49 2680 181-0.

A list of authorised sales partners can be found at www.ewm-group.com/en/specialist-dealers.

Liability relating to the operation of this equipment is restricted solely to the function of the equipment. No other form of liability, regardless of type, shall be accepted. This exclusion of liability shall be deemed accepted by the user on commissioning the equipment.

The manufacturer is unable to monitor whether or not these instructions or the conditions and methods are observed during installation, operation, usage and maintenance of the equipment.

An incorrectly performed installation can result in material damage and injure persons as a result. For this reason, we do not accept any responsibility or liability for losses, damages or costs arising from incorrect installation, improper operation or incorrect usage and maintenance or any actions connected to this in any way.

© EWM GmbH

Dr. Günter-Henle-Strasse 8

56271 Mündersbach Germany

Tel.: +49 2680 181-0, Fax: -244

Email: info@ewm-group.com

www.ewm-group.com

The copyright to this document remains the property of the manufacturer.

Copying, including extracts, only permitted with written approval.

The content of this document has been prepared and reviewed with all reasonable care. The information provided is subject to change; errors excepted.

Data security

The user is responsible for backing up data of all changes from the factory setting. The user is liable for erased personal settings. The manufacturer does not assume any liability for this.

1 Contents

1	Contents	3
2	For your safety	5
2.1	Notes on using these operating instructions	5
2.2	Explanation of icons	6
2.3	Safety instructions	7
2.4	Transport and installation	10
3	Intended use	12
3.1	Applications	12
3.1.1	Picomig 220 puls TKG	12
3.1.2	Picomig 220 Synergic TKG	12
3.2	Documents which also apply	12
3.2.1	Warranty	12
3.2.2	Declaration of Conformity	12
3.2.3	Welding in environments with increased electrical hazards	12
3.2.4	Service documents (spare parts and circuit diagrams)	12
3.2.5	Calibration/Validation	12
3.2.6	Part of the complete documentation	13
4	Machine description – quick overview	14
4.1	Front view	14
4.2	Inside view	16
5	Design and function	18
5.1	Transport and installation	18
5.1.1	Ambient conditions	18
5.1.2	Machine cooling	18
5.1.3	Workpiece lead, general	19
5.1.4	Notes on the installation of welding current leads	19
5.1.5	Stray welding currents	21
5.1.6	Mains connection	22
5.1.6.1	Mains configuration	22
5.1.7	Shielding gas supply (shielding gas cylinder for welding machine)	23
5.1.7.1	Pressure regulator connection	23
5.1.7.2	Shielding gas hose connection	24
5.1.7.3	Gas test – setting the shielding gas volume	24
5.1.8	Dirt filter	24
5.2	MIG/MAG welding	25
5.2.1	Welding torch and workpiece line connection	25
5.2.2	Wire feed	27
5.2.2.1	Inserting the wire spool	27
5.2.2.2	Changing the wire feed rollers	28
5.2.2.3	Inching the wire electrode	28
5.2.2.4	Spool brake setting	29
5.2.3	Welding task selection	30
5.3	MMA welding	30
5.3.1	Connecting the electrode holder and workpiece lead	30
5.3.2	Welding task selection	30
5.4	TIG welding	31
5.4.1	Preparing the TIG welding torch	31
5.4.2	Welding torch and workpiece line connection	31
5.4.3	Welding task selection	31
6	Maintenance, care and disposal	32
6.1	General	32
6.2	Explanation of icons	32
6.3	Maintenance schedule	33
6.4	Disposing of equipment	34
7	Rectifying faults	35
7.1	Software version of the machine control	35
7.2	Error messages (power source)	35

7.3	Checklist for rectifying faults	36
7.4	Dynamic power adjustment.....	37
7.5	Resetting welding parameters to the factory settings	38
8	Technical data.....	39
8.1	Picomig 220	39
9	Accessories	40
9.1	Transport system	40
9.2	Shielding gas supply (shielding gas cylinder for welding machine).....	40
9.3	Option for retrofitting	40
9.4	General accessories	40
10	Replaceable parts.....	41
10.1	Wire feed rollers	41
10.1.1	Wire feed rollers for steel wire	41
10.1.2	Wire feed rollers for aluminium wire	41
10.1.3	Wire feed rollers for cored wire.....	41
10.1.4	Conversion kit.....	41
11	Appendix	42
11.1	Average wire electrode usage	42
11.2	Average shielding gas usage.....	42
11.2.1	MIG/MAG welding.....	42
11.2.2	TIG welding.....	42
11.3	Searching for a dealer.....	43

2 For your safety

2.1 Notes on using these operating instructions

DANGER

Working or operating procedures which must be closely observed to prevent imminent serious and even fatal injuries.

- Safety notes include the "DANGER" keyword in the heading with a general warning symbol.
- The hazard is also highlighted using a symbol on the edge of the page.

WARNING

Working or operating procedures which must be closely observed to prevent serious and even fatal injuries.

- Safety notes include the "WARNING" keyword in the heading with a general warning symbol.
- The hazard is also highlighted using a symbol in the page margin.

CAUTION

Working or operating procedures which must be closely observed to prevent possible minor personal injury.

- The safety information includes the "CAUTION" keyword in its heading with a general warning symbol.
- The risk is explained using a symbol on the edge of the page.



Technical aspects which the user must observe to avoid material or equipment damage.

Instructions and lists detailing step-by-step actions for given situations can be recognised via bullet points, e.g.:

- Insert the welding current lead socket into the relevant socket and lock.

2.2 Explanation of icons

Symbol	Description	Symbol	Description
	Indicates technical aspects which the user must observe.		Activate and release / Tap / Tip
	Switch off machine		Release
	Switch on machine		Press and hold
	Incorrect / Invalid		Switch
	Correct / Valid		Turn
	Input		Numerical value – adjustable
	Navigation		Signal light lights up in green
	Exit		Signal light flashes green
	Time representation (e.g.: wait 4 s / actuate)		Signal light lights up in red
	Interruption in the menu display (other setting options possible)		Signal light flashes red
	Tool not required/do not use		Signal light lights up in blue
	Tool required/use		Signal light flashes blue

2.3 Safety instructions

WARNING



Risk of accidents due to non-compliance with the safety instructions!
Non-compliance with the safety instructions can be fatal!

- Carefully read the safety instructions in this manual!
- Observe the accident prevention regulations and any regional regulations!
- Inform persons in the working area that they must comply with the regulations!



Risk of injury from electrical voltage!

Voltages can cause potentially fatal electric shocks and burns on contact. Even low voltages can cause a shock and lead to accidents.

- Never touch live components such as welding current sockets or stick, tungsten or wire electrodes!
- Always place torches and electrode holders on an insulated surface!
- Wear the full personal protective equipment (depending on the application)!
- The machine may only be opened by qualified personnel!
- The device must not be used to defrost pipes!



Hazard when interconnecting multiple power sources!

If a number of power sources are to be connected in parallel or in series, only a technical specialist may interconnect the sources as per standard IEC 60974-9:2010: Installation and use and German Accident Prevention Regulation BVG D1 (formerly VBG 15) or country-specific regulations.

Before commencing arc welding, a test must verify that the equipment cannot exceed the maximum permitted open circuit voltage.

- Only qualified personnel may connect the machine.
- When taking individual power sources out of operation, all mains and welding current leads must be safely disconnected from the welding system as a whole. (Hazard due to reverse polarity voltage!)
- Do not interconnect welding machines with pole reversing switch (PWS series) or machines for AC welding since a minor error in operation can cause the welding voltages to be combined, which is not permitted.



Risk of injury due to radiation or heat!

Arc radiation can lead to skin and eye injuries.

Contact with hot workpieces and sparks can lead to burns.

- Use hand shield or welding helmet with the appropriate safety level (depends on the application).
- Wear dry protective clothing (e.g. hand shield, gloves, etc.) in accordance with the applicable regulations of your country.
- Persons who are not directly involved should be protected with a welding curtain or suitable safety screen against radiation and the risk of blinding!

WARNING



Risk of injury due to improper clothing!

During arc welding, radiation, heat and voltage are sources of risk that cannot be avoided. The user has to be equipped with the complete personal protective equipment at all times. The protective equipment has to include:

- Respiratory protection against hazardous substances and mixtures (fumes and vapours); otherwise implement suitable measures such as extraction facilities.
- Welding helmet with proper protection against ionizing radiation (IR and UV radiation) and heat.
- Dry welding clothing (shoes, gloves and body protection) to protect against warm environments with conditions comparable to ambient temperatures of 100 °C or higher and arcing and work on live components.
- Hearing protection against harming noise.



Explosion risk!

Apparently harmless substances in closed containers may generate excessive pressure when heated.

- Move containers with inflammable or explosive liquids away from the working area!
- Never heat explosive liquids, dusts or gases by welding or cutting!



Fire hazard!

Due to the high temperatures, sparks, glowing parts and hot slag that occur during welding, there is a risk of flames.

- Be watchful of potential sources of fire in the working area!
- Do not carry any easily inflammable objects, e.g. matches or lighters.
- Ensure suitable fire extinguishers are available in the working area!
- Thoroughly remove any residue of flammable materials from the workpiece prior to starting to weld.
- Only further process workpieces after they have cooled down. Do not allow them to contact any flammable materials!

⚠ CAUTION**Smoke and gases!**

Smoke and gases may lead to shortness of breath and poisoning! The ultraviolet radiation of the arc may also convert solvent vapours (chlorinated hydrocarbon) into poisonous phosgene.

- Ensure sufficient fresh air!
- Keep solvent vapours away from the arc beam field!
- Wear suitable respiratory protection if necessary!
- To prevent the formation of phosgene, residues of chlorinated solvents on workpieces must first be neutralised using appropriate measures.

**Noise exposure!**

Noise exceeding 70 dBA can cause permanent hearing damage!

- Wear suitable ear protection!
- Persons located within the working area must wear suitable ear protection!



According to IEC 60974-10, welding machines are divided into two classes of electromagnetic compatibility (the EMC class can be found in the Technical data) > see 8 chapter:



Class A machines are not intended for use in residential areas where the power supply comes from the low-voltage public mains network. When ensuring the electromagnetic compatibility of class A machines, difficulties can arise in these areas due to interference not only in the supply lines but also in the form of radiated interference.



Class B machines fulfil the EMC requirements in industrial as well as residential areas, including residential areas connected to the low-voltage public mains network.

Setting up and operating

When operating arc welding systems, in some cases, electro-magnetic interference can occur although all of the welding machines comply with the emission limits specified in the standard. The user is responsible for any interference caused by welding.

In order to **evaluate** any possible problems with electromagnetic compatibility in the surrounding area, the user must consider the following: (see also EN 60974-10 Appendix A)

- Mains, control, signal and telecommunication lines
- Radios and televisions
- Computers and other control systems
- Safety equipment
- The health of neighbouring persons, especially if they have a pacemaker or wear a hearing aid
- Calibration and measuring equipment
- The immunity to interference of other equipment in the surrounding area
- The time of day at which the welding work must be carried out

Recommendations for reducing interference emission

- Mains connection, e.g. additional mains filter or shielding with a metal tube
- Maintenance of the arc welding system
- Welding leads should be as short as possible and run closely together along the ground
- Potential equalization
- Earthing of the workpiece. In cases where it is not possible to earth the workpiece directly, it should be connected by means of suitable capacitors.
- Shielding from other equipment in the surrounding area or the entire welding system

**Electromagnetic fields!**

The power source can create electrical or electromagnetic fields that may impair the function of electronic systems such as EDP and CNC devices, telecommunication, power and signal lines as well as pacemakers and defibrillators.



- Follow the maintenance instructions > see 6 chapter!
- Unwind the welding leads completely!
- Shield radiation-sensitive equipment or facilities appropriately!
- The function of pacemakers may be impaired (seek medical advice if necessary).

CAUTION



Obligations of the operator!

The respective national directives and laws must be complied with when operating the machine!

- Implementation of national legislation relating to framework directive 89/391/EEC on the introduction of measures to encourage improvements in the safety and health of workers at work and associated individual guidelines.
- In particular, directive 89/655/EEC concerning the minimum safety and health requirements for the use of work equipment by workers at work.
- The regulations applicable to occupational safety and accident prevention in the country concerned.
- Setting up and operating the machine as per IEC 60974.-9.
- Brief the user on safety-conscious work practices on a regular basis.
- Regularly inspect the machine as per IEC 60974.-4.



The manufacturer's warranty becomes void if non-genuine parts are used!

- ***Only use system components and options (power sources, welding torches, electrode holders, remote controls, spare parts and replacement parts, etc.) from our range of products!***
- ***Only insert and lock accessory components into the relevant connection socket when the machine is switched off.***

Requirements for connection to the public mains network

High-performance machines can influence the mains quality by taking current from the mains network. For some types of machines, connection restrictions or requirements relating to the maximum possible line impedance or the necessary minimum supply capacity at the interface with the public network (Point of Common Coupling, PCC) can therefore apply. In this respect, attention is also drawn to the machines' technical data. In this case, it is the responsibility of the operator, where necessary in consultation with the mains network operator, to ensure that the machine can be connected.

2.4 Transport and installation

WARNING



Risk of injury due to improper handling of shielding gas cylinders!

Improper handling and insufficient securing of shielding gas cylinders can cause serious injuries!

- Observe the instructions from the gas manufacturer and any relevant regulations concerning the use of compressed air!
- Do not attach any element to the shielding gas cylinder valve!
- Prevent the shielding gas cylinder from heating up.

⚠ CAUTION**Risk of accidents due to supply lines!**

During transport, attached supply lines (mains leads, control cables, etc.) can cause risks, e.g. by causing connected machines to tip over and injure persons!

- Disconnect all supply lines before transport!

**Risk of tipping!**

There is a risk of the machine tipping over and injuring persons or being damaged itself during movement and set up. Tilt resistance is guaranteed up to an angle of 10° (according to IEC 60974-1).

- Set up and transport the machine on level, solid ground.
- Secure add-on parts using suitable equipment.

**Risk of accidents due to incorrectly installed leads!**

Incorrectly installed leads (mains, control and welding leads or intermediate hose packages) can present a tripping hazard.

- Lay the supply lines flat on the floor (avoid loops).
- Avoid laying the leads on passage ways.

**Risk of injury from heated coolant and its connections!**

The coolant used and its connection or connection points can heat up significantly during operation (water-cooled version). When opening the coolant circuit, escaping coolant may cause scalding.

- Open the coolant circuit only when the power source or cooling unit is switched off!
- Wear proper protective equipment (protective gloves)!
- Seal open connections of the hose leads with suitable plugs.



The units are designed for operation in an upright position!

Operation in non-permissible positions can cause equipment damage.

- ***Only transport and operate in an upright position!***



Accessory components and the power source itself can be damaged by incorrect connection!

- ***Only insert and lock accessory components into the relevant connection socket when the machine is switched off.***
- ***Comprehensive descriptions can be found in the operating instructions for the relevant accessory components.***
- ***Accessory components are detected automatically after the power source is switched on.***



Protective dust caps protect the connection sockets and therefore the machine against dirt and damage.

- ***The protective dust cap must be fitted if there is no accessory component being operated on that connection.***
- ***The cap must be replaced if faulty or if lost!***

3 Intended use

WARNING



Hazards due to improper usage!

The machine has been constructed to the state of the art and any regulations and standards applicable for use in industry and trade. It may only be used for the welding procedures indicated at the rating plate. Hazards may arise for persons, animals and material objects if the equipment is not used correctly. No liability is accepted for any damages arising from improper usage!

- The equipment must only be used in line with its designated purpose and by trained or expert personnel!
- Do not improperly modify or convert the equipment!

3.1 Applications

3.1.1 Picomig 220 puls TKG

Arc welding machine for standard and pulsed gas-shielded metal-arc welding with TIG welding and lift arc (touch starting) or MMA welding as secondary process. It may be possible to expand the functionality by using accessories (see the documentation in the relevant chapter).

3.1.2 Picomig 220 Synergic TKG

Arc welding machine for GMAW standard welding and in the secondary process TIG welding with Liftarc (contact ignition) or MMA welding. Accessory components may expand the range of functions (see the relevant documentation in the chapter of the same name).

3.2 Documents which also apply

3.2.1 Warranty

For more information refer to the "Warranty registration" brochure supplied and our information regarding warranty, maintenance and testing at www.ewm-group.com!

3.2.2 Declaration of Conformity



This product corresponds in its design and construction to the EU directives listed in the declaration. The product comes with a relevant declaration of conformity in the original.

The manufacturer recommends carrying out the safety inspection according to national and international standards and guidelines every 12 months (from commissioning).

3.2.3 Welding in environments with increased electrical hazards



Power sources with this marking can be used for welding in an environment with increased electrical hazard (e.g. boilers). For this purpose, appropriate national or international regulations must be followed. The power source must not be placed in the danger zone!

3.2.4 Service documents (spare parts and circuit diagrams)

WARNING



No improper repairs and modifications!

To prevent injuries and damage to the machine, only competent personnel (authorised service personnel) are allowed to repair or modify the machine. Unauthorised manipulations will invalidate the warranty!

- Instruct competent personnel (authorised service personnel) to repair the machine.

Original copies of the circuit diagrams are enclosed with the unit.

Spare parts can be obtained from the relevant authorised dealer.

3.2.5 Calibration/Validation

An original certificate is enclosed with the product. The manufacturer recommends calibration / validation at intervals of 12 months (from commissioning).

3.2.6 Part of the complete documentation

This document is part of the complete documentation and valid only in combination with all other parts of these instructions! Read and observe the operating instructions for all system components, especially the safety instructions!

The illustration shows a general example of a welding system.

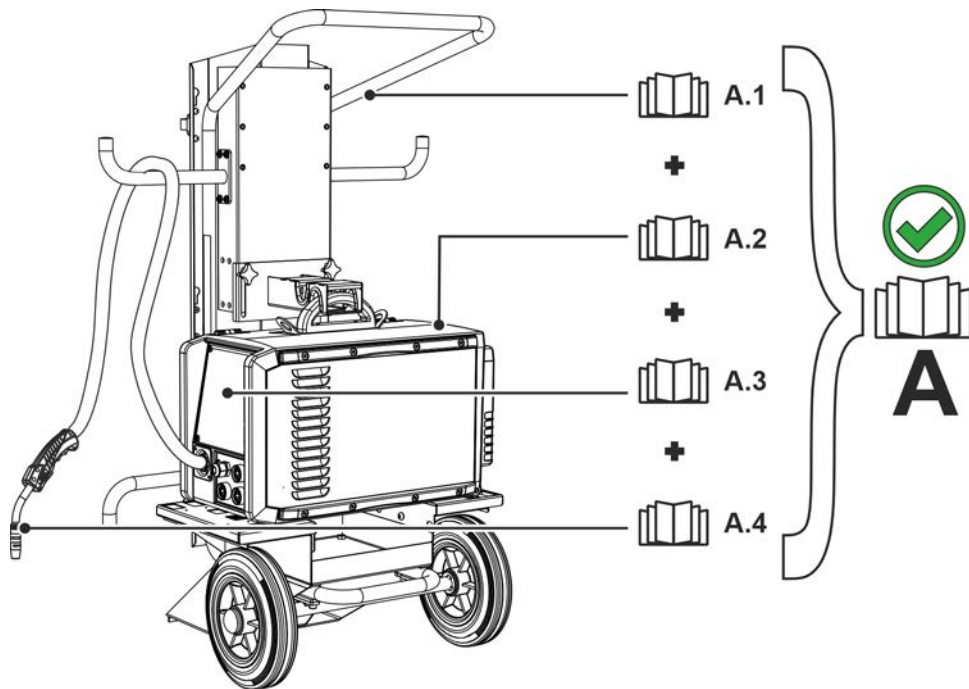

Figure 3-1

Item	Documentation
A.1	Transport cart
A.2	Power source
A.3	Controller
A.4	Welding torch
A	Complete documentation

4 Machine description – quick overview

4.1 Front view

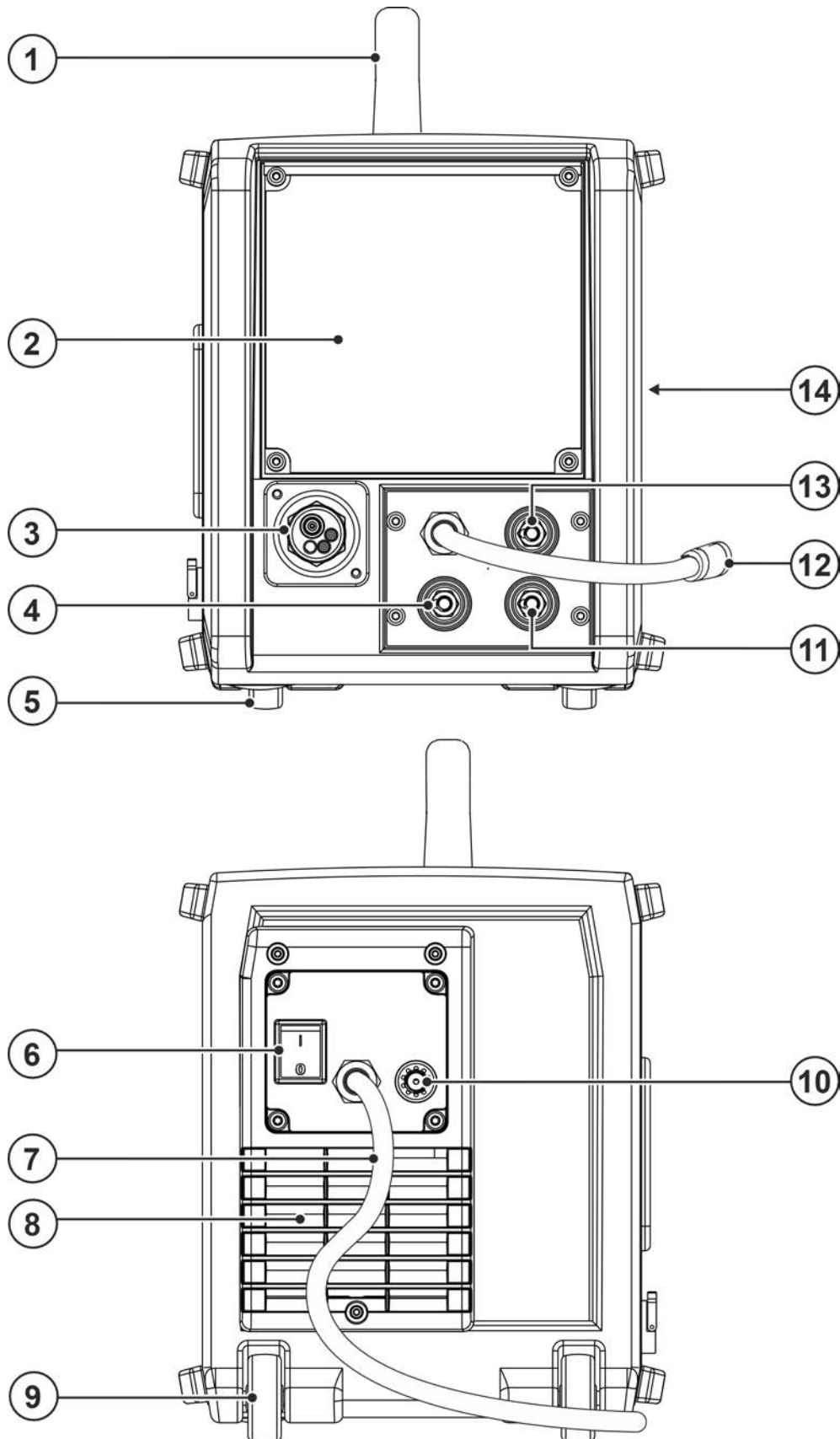





Figure 4-1

Item	Symbol	Description
1		Carrying handle
2		Machine control (see the relevant control operating instructions)
3		Welding torch connection - Euro torch connector Welding current, shielding gas and torch trigger integrated
4		Connection socket (+) welding current <ul style="list-style-type: none"> •-----MIG/MAG cored wire welding: Workpiece connection •-----TIG welding: Workpiece connection •-----MMA welding: Workpiece connection
5		Machine feet
6		Main Switch Switching the machine on or off.
7		Mains connection cable with connector plug
8		Cooling air inlet
9		Wheels
10		Connection thread - G¼" Shielding gas connection (inlet)
11		(-) welding current connection socket <ul style="list-style-type: none"> •-----MIG/MAG welding: Workpiece connection •-----TIG welding: Welding current connection for welding torch •-----MMA welding: electrode holder connection
12		Polarity selection plug welding current cable
13		Park socket - polarity selection plug Retainer for the polarity selection plug in MMA mode or for transport.
14		Cooling air outlet

4.2 Inside view

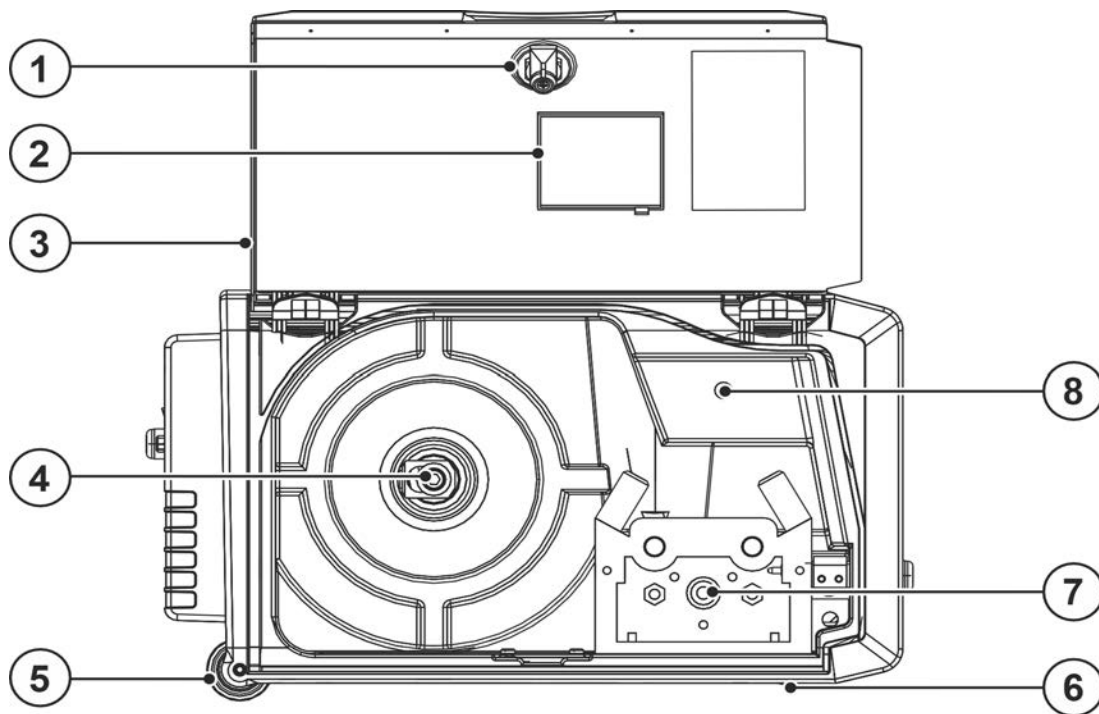



Figure 4-2

Item	Symbol	Description
1		Rotary closure Locking of the protective cap
2		Wire spool inspection window Check wire supply
3		Protective cap Cover for the wire feed mechanism and other operating elements. Depending on the machine series, additional stickers with information on the replacement parts and JOB lists will be located on the inside.
4		Wire spool holder
5		Wheels
6		Machine feet
7		Wire feed unit > see 5.2.2 chapter
8		Push-button wire inching Potential- and gas-free inching of the wire electrode through the hose package to the welding torch > see 5.2.2.3 chapter.

5 Design and function

WARNING



Risk of injury from electrical voltage!

Contact with live parts, e.g. power connections, can be fatal!

- Observe the safety information on the first pages of the operating instructions!
- Commissioning must be carried out by persons who are specifically trained in handling power sources!
- Connect connection or power cables while the machine is switched off!

Read and observe the documentation to all system and accessory components!

5.1 Transport and installation

WARNING



Risk of accident due to improper transport of machines that must not be lifted!

Do not lift or suspend the machine! The machine can drop and cause injuries! The handles, straps or brackets are suitable for transport by hand only!

- The machine must not be suspended or lifted using a crane.

5.1.1 Ambient conditions



The machine must not be operated in the open air and must only be set up and operated on a suitable, stable and level base!

- ***The operator must ensure that the ground is non-slip and level, and provide sufficient lighting for the place of work.***
- ***Safe operation of the machine must be guaranteed at all times.***



Machine damage due to contamination!

Unusually high amounts of dust, acid, corrosive gas or substances may damage the machine (note the maintenance intervals > see 6.3 chapter).

- ***Prevent high amounts of smoke, weld spatter, steam, oil vapour, grinding dust and corrosive ambient air from developing!***

In operation

Temperature range of the ambient air:

- -25 °C to +40 °C (-13 °F to 104 °F) ^[1]

Relative humidity:

- up to 50 % at 40 °C (104 °F)
- up to 90 % at 20 °C (68 °F)

Transport and storage

Storage in a closed room, temperature range of the ambient air:

- -30 °C to +70 °C (-22 °F to 158 °F) ^[1]

Relative humidity

- up to 90 % at 20 °C (68 °F)

^[1] Ambient temperature dependent on coolant! Observe the coolant temperature range of the torch cooling

5.1.2 Machine cooling



Insufficient ventilation results in a reduction in performance and equipment damage.

- ***Observe the ambient conditions!***
- ***Keep the cooling air inlet and outlet clear!***
- ***Observe the minimum distance of 0.5 m from obstacles!***

5.1.3 Workpiece lead, general

⚠ CAUTION



Risk of burning due to incorrect welding current connection!

If the welding current plugs (machine connections) are not locked or if the workpiece connection is contaminated (paint, corrosion), these connections and leads can heat up and cause burns when touched!

- Check welding current connections on a daily basis and lock by turning to the right when necessary.
- Clean workpiece connection thoroughly and secure properly. Do not use structural parts of the workpiece as welding current return lead!

5.1.4 Notes on the installation of welding current leads

- Incorrectly installed welding current leads can cause faults in the arc (flickering).
- Lay the workpiece lead and hose package of power sources without HF igniter (MIG/MAG) for as long and as close as possible in parallel.
- Lay the workpiece lead and hose package of power sources with HF igniter (TIG) for as long as possible in parallel with a distance of 20 cm to avoid HF sparkover.
- Always keep a distance of at least 20 cm to leads of other power sources to avoid interferences
- Always keep leads as short as possible! For optimum welding results max. 30 m (welding lead + intermediate hose package + torch lead).

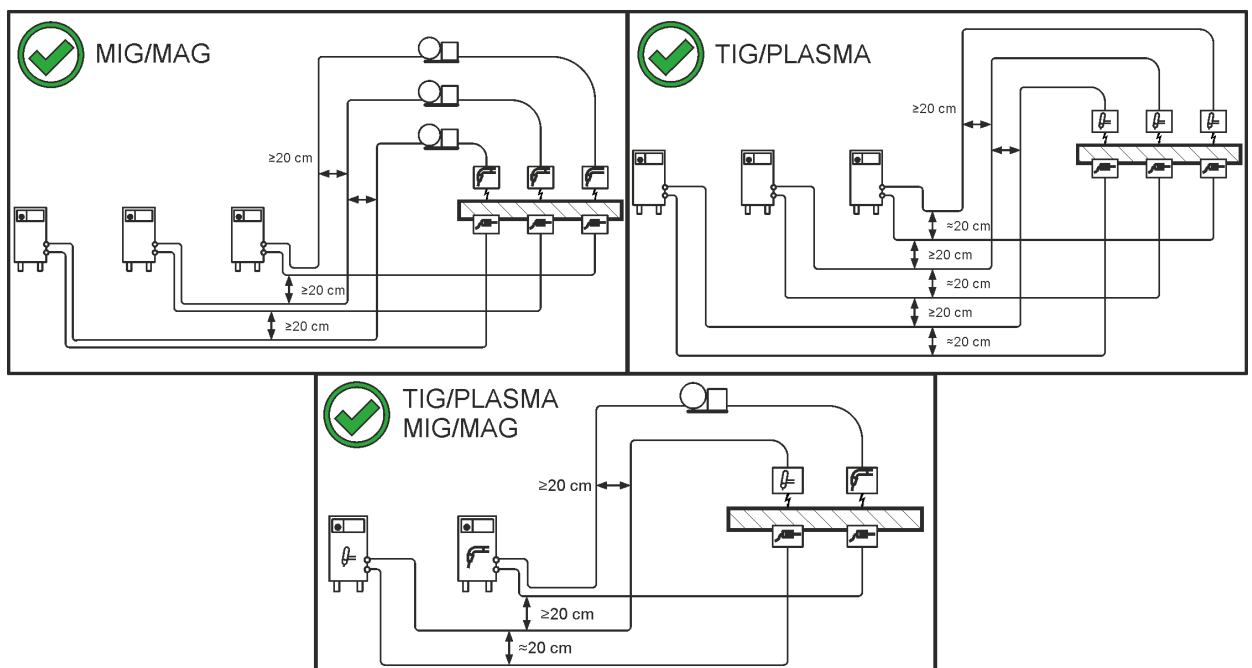

Figure 5-1

- Use an individual welding lead to the workpiece for each welding machine!

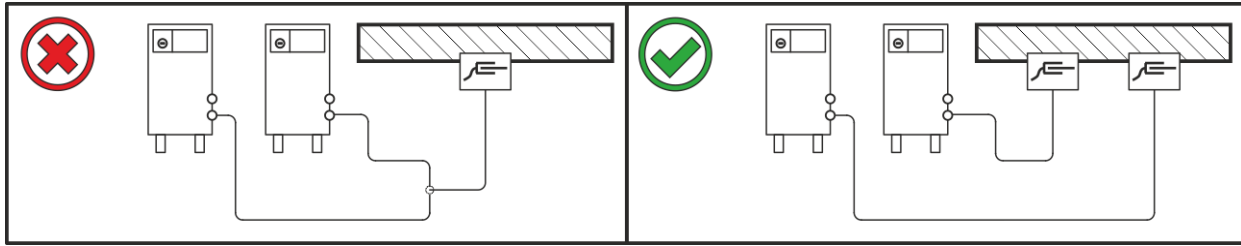

Figure 5-2

- Fully unroll welding current leads, torch hose packages and intermediate hose packages. Avoid loops!
- Always keep leads as short as possible!

Lay any excess cable lengths in meanders.

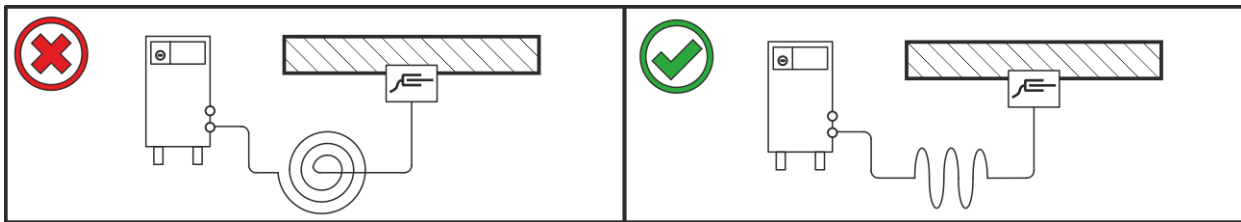

Figure 5-3

5.1.5 Stray welding currents

⚠ WARNING



Risk of injury due to stray welding currents!

Stray welding currents can destroy protective earth conductors, damage machines and electronic devices and cause overheating of components, leading to fire.

- Check that all welding current connections are firmly secured and electrical connections are in perfect condition.
- Set up, attach or suspend all conductive power source components such as casing, transport vehicles and crane frames so they are insulated.
- Do not place any other electronic devices such as drills or angle grinders on the power source, transport vehicle or crane frames unless they are insulated.
- Always put welding torches and electrode holders on an insulated surface when they are not in use.

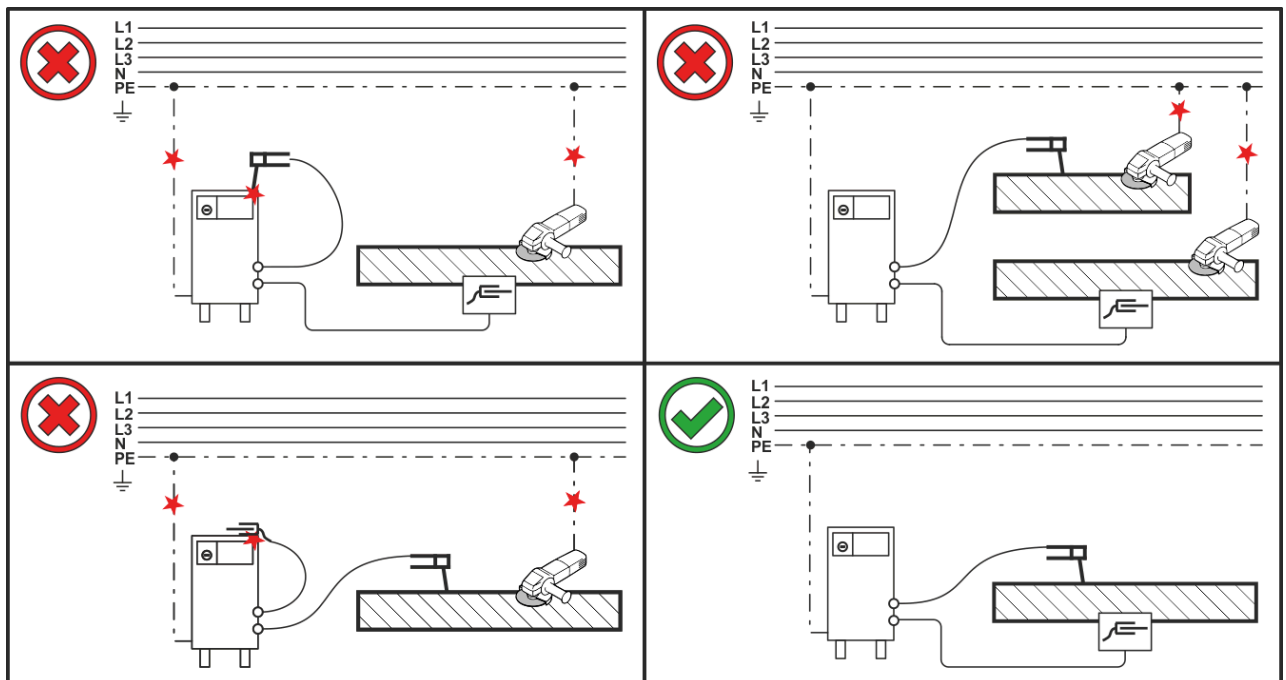

Figure 5-4

5.1.6 Mains connection

DANGER



Hazards caused by improper mains connection!

An improper mains connection can cause injuries or damage property!

- The connection (mains plug or cable), the repair or voltage adjustment of the device must be carried out by a qualified electrician in accordance with the respective local laws or national regulations!
- The mains voltage indicated on the rating plate must match the supply voltage.
- Only operate machine using a socket that has correctly fitted protective earth.
- Mains plug, socket and lead must be checked by a qualified electrician on a regular basis!
- When operating the generator, always ensure it is earthed as stipulated in the operating instructions. The network created must be suitable for operating machines according to protection class I.

5.1.6.1 Mains configuration



The machine may only be connected to a one-phase system with two conductors and an earthed neutral conductor.

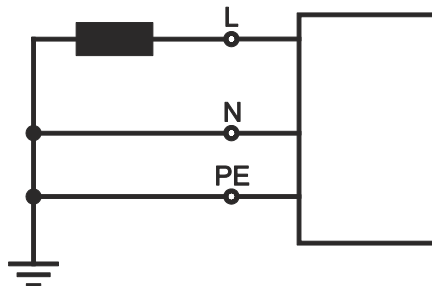

Figure 5-5

Legend

Item	Designation	Colour code
L	Outer conductor	brown
N	Neutral conductor	blue
PE	Protective conductor	green-yellow

- Insert mains plug of the switched-off machine into the appropriate socket.

5.1.7 Shielding gas supply (shielding gas cylinder for welding machine)

⚠ WARNING



Risk of injury due to improper handling of shielding gas cylinders! Improper handling and insufficient securing of shielding gas cylinders can cause serious injuries!

- Place shielding gas cylinder into the designated holder and secure with fastening elements (chain/belt)!
- Attach the fastening elements within the upper half of the shielding gas cylinder!
- The fastening elements must tightly enclose the shielding gas cylinder!

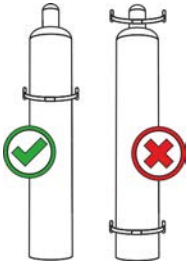



An unhindered shielding gas supply from the shielding gas cylinder to the welding torch is a fundamental requirement for optimum welding results. In addition, a blocked shielding gas supply may result in the welding torch being destroyed.

- **Always re-fit the yellow protective cap when not using the shielding gas connection.**
- **All shielding gas connections must be gas tight.**

5.1.7.1 Pressure regulator connection

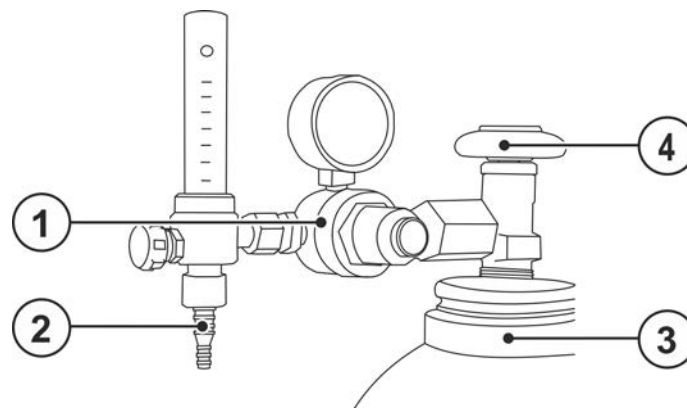

Figure 5-6

Item	Symbol	Description
1		Pressure regulator
2		Output side of the pressure regulator
3		Shielding gas cylinder
4		Cylinder valve

- Before connecting the pressure regulator to the gas cylinder, open the cylinder valve briefly to blow out any dirt.
- Tighten the pressure regulator screw connection on the gas bottle valve to be gas-tight.
- Screw the gas hose connection to the outlet side of the pressure regulator gas-tight.

5.1.7.2 Shielding gas hose connection

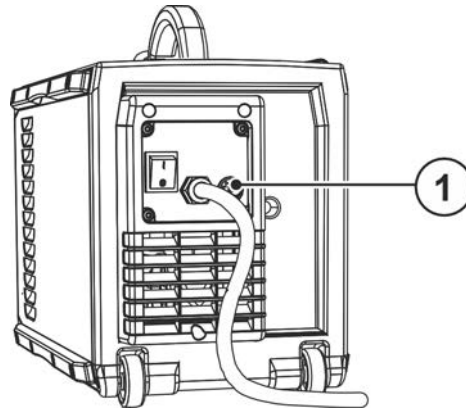

Figure 5-7

Item	Symbol	Description
1		Connection thread - G$\frac{1}{4}$" Shielding gas connection (inlet)

- Screw the gas hose connection to the shielding gas connection (inlet) on the machine gas-tight.

5.1.7.3 Gas test – setting the shielding gas volume

If the shielding gas setting is too low or too high, this can introduce air to the weld pool and may cause pores to form. Adjust the shielding gas quantity to suit the welding task!

- Slowly open the gas cylinder valve.
- Open the pressure regulator.
- Switch on the power source at the main switch.
- Set the relevant gas quantity for the application on the pressure regulator.
- You can activate the gas test by briefly pressing the “Gas test ” push-button on the machine control (welding voltage and wire feed motor remain switched off – no unintentional ignition of the arc).

Shielding gas flows for around 25 seconds or until the button is pressed again.

Repeat rinsing process several times.

Setting instructions

Welding process	Recommended shielding gas quantity
MAG welding	Wire diameter x 11.5 = l/min
MIG brazing	Wire diameter x 11.5 = l/min
MIG welding (aluminium)	Wire diameter x 13.5 = l/min (100 % argon)
TIG	Gas nozzle diameter in mm corresponds to l/min gas throughput

Helium-rich gas mixtures require a higher gas volume!

The table below can be used to correct the gas volume calculated where necessary:

Shielding gas	Factor
75% Ar/25% He	1.14
50% Ar/50% He	1.35
25% Ar/75% He	1.75
100% He	3.16

5.1.8 Dirt filter

These accessory components can be retrofitted as an option > see 9 chapter.

When using a dirt filter, the cooling air throughput is reduced and the duty cycle of the machine is reduced as a result. The duty cycle decreases with the increasing contamination of the filter. The dirt filter must be removed at regular intervals and cleaned by blowing out with compressed air (depending on the level of soiling).

5.2 MIG/MAG welding

5.2.1 Welding torch and workpiece line connection

On delivery, the Euro torch connector is fitted with a capillary tube for welding torches with a steel liner. Conversion is necessary if a welding torch with a liner is used!

- Operate welding torches with a liner > with a guide tube.
- Operate welding torches with a steel liner > with a capillary tube.

For connection, observe the operating instructions for the welding torch.

Depending on the wire electrode diameter or type, either a steel liner or liner with the correct inner diameter must be inserted in the torch!

Recommendation:

- Use a steel liner when welding hard, unalloyed wire electrodes (steel).
- Use a chrome nickel liner when welding hard, high-alloy wire electrodes (CrNi).
- Use a plastic or teflon liner when welding or brazing soft wire electrodes, high-alloy wire electrodes or aluminium materials.

Preparation for connecting welding torches with a spiral guide:

- Check that the capillary tube is correctly positioned in relation to the central connector!

Preparation for connecting welding torches with a liner:

- Push forward the capillary tube on the wire feed side in the direction of the Euro torch connector and remove it there.
- Insert the liner guide tube from the Euro torch connector side.
- Carefully insert the welding torch connector with as yet too long a liner into the Euro torch connector and secure with a crown nut.
- Cut off the liner with a liner cutter > *see 9 chapter* just before the wire feed roller.
- Loosen the welding torch connector and remove.
- Carefully chamfer the cut off end of the liner with a liner sharpener > *see 9 chapter* and sharpen.

Choose welding current connection socket according to the signal light for the polarity setting!

- Select JOB > see 5.2.3 chapter
- Polarity selection “+” or polarity selection “-” signal lights show the polarity setting.

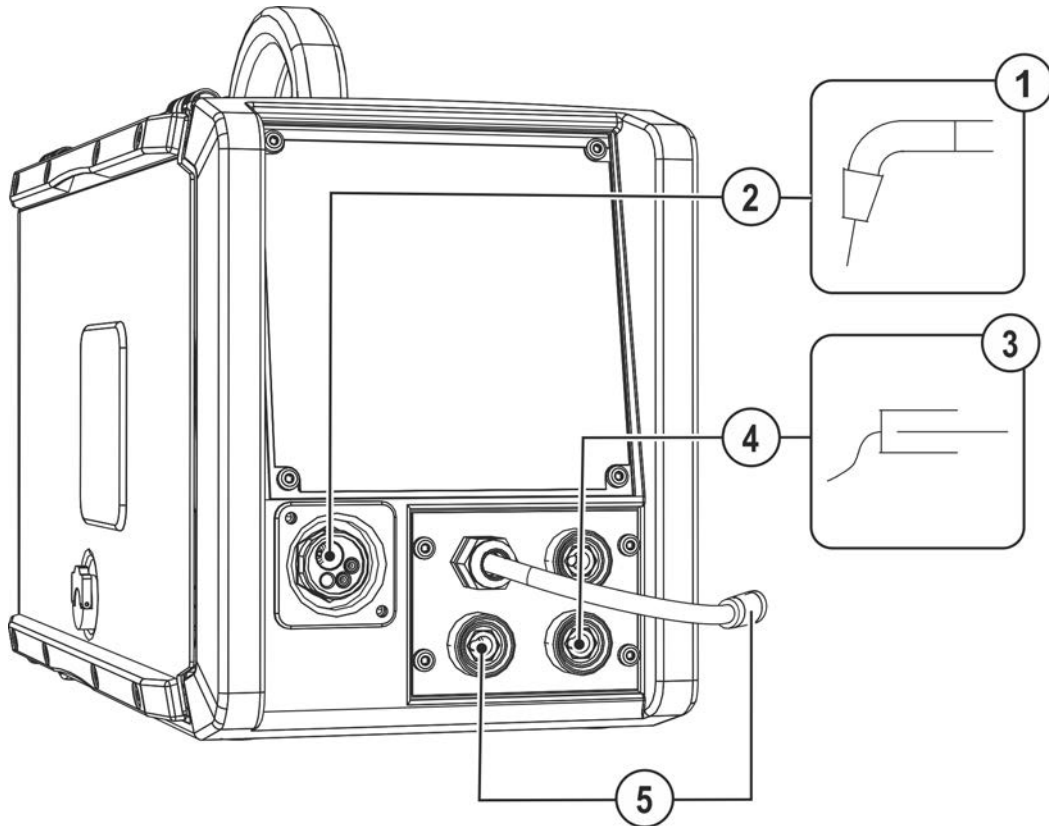

Figure 5-8

Item	Symbol	Description
1		Welding torch
2		Welding torch connection - Euro torch connector Welding current, shielding gas and torch trigger integrated
3		Workpiece
4		(-) welding current connection socket • ----- MIG/MAG welding: Workpiece connection
5		Polarity selector plug welding current cable Internal welding current cable for central connection/welding torch. • Connection socket for (+) welding current

- Insert the central plug for the welding torch into the central connector and screw together with crown nut.
- Insert the plug of the workpiece lead in the respective welding current connection socket and lock in place by turning to the right.
- Insert the polarity selection plug in the respective welding current connection socket and lock in place by turning to the right.

Some wire electrodes (for example self-shielded flux cored wire) must be welded with negative polarity (follow the electrode manufacturer's instructions). In this case, the polarity selection plug must be plugged into the “-” welding current socket and the workpiece lead into the “+” welding current socket and locked.

5.2.2 Wire feed

⚠ CAUTION**Risk of injury due to moving parts!**

The wire feeders are equipped with moving parts, which can trap hands, hair, clothing or tools and thus injure persons!

- Do not reach into rotating or moving parts or drive components!
- Keep casing covers or protective caps closed during operation!

**Risk of injury due to welding wire escaping in an unpredictable manner!**

Welding wire can be conveyed at very high speeds and, if conveyed incorrectly, may escape in an uncontrolled manner and injure persons!

- Before mains connection, set up the complete wire guide system from the wire spool to the welding torch!
- Check wire guide at regular intervals!
- Keep all casing covers or protective caps closed during operation!

5.2.2.1 Inserting the wire spool

⚠ CAUTION**Risk of injury due to incorrectly secured wire spool.**

If the wire spool is not secured properly, it may come loose from the wire spool support and fall to the ground, causing damage to the machine and injuries.

- Make sure to correctly fasten the wire spool to the wire spool support.
- Before you start working, always check the wire spool is securely fastened.

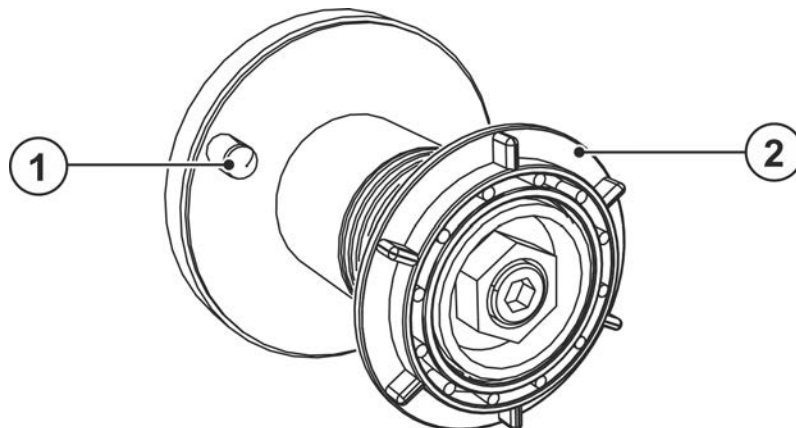

Figure 5-9

Item	Symbol	Description
1		Carrier pin For fixing the wire spool
2		Knurled nut For fixing the wire spool

- Unlock and open protective flap.
- Loosen knurled nut from spool holder.
- Fix welding wire reel onto the spool holder so that the carrier pin locks into the spool bore.
- Fasten wire spool using knurled nut.

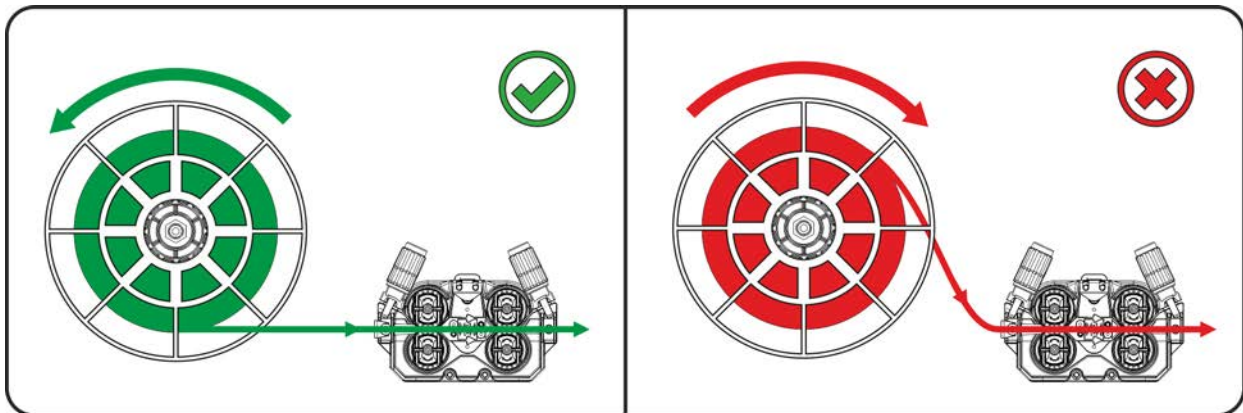

Figure 5-10

Observe the unwinding direction of the wire spool.

5.2.2.2 Changing the wire feed rollers

Poor welding results due to faulty wire feeding! Wire feed rolls must be suitable for the diameter of the wire and the material.

- Check the label of the rolls whether they fit the wire diameter. If necessary, turn or change!
- Use V-groove rolls for steel wires and other hard wires.
- Use driven rolls with U-groove for aluminium wires and other soft, alloyed wires.
- Use driven rolls with knurled U-groove for flux cored wires.
- Slide new drive rollers into place so that the diameter of the wire used is visible on the drive roller.
- Screw the drive rollers in place with knurled screws.

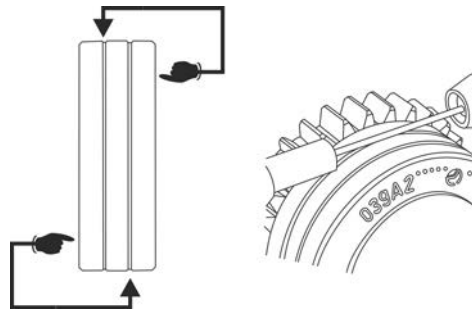

Figure 5-11

5.2.2.3 Inching the wire electrode

⚠ CAUTION



Risk of injury due to welding wire escaping from the welding torch!

The welding wire can escape from the welding torch at high speed and cause bodily injury including injuries to the face and eyes!

- Never direct the welding torch towards your own body or towards other persons!



Improper contact pressure increases wear on the wire feed rolls.

Adjust the contact pressure on the adjusting nuts of the feed roll tensioners so that the wire electrode is fed but slips when the wire spool is blocked.

The inching speed is infinitely adjustable by simultaneously pressing the wire inching push-button and turning the wire speed rotary knob.

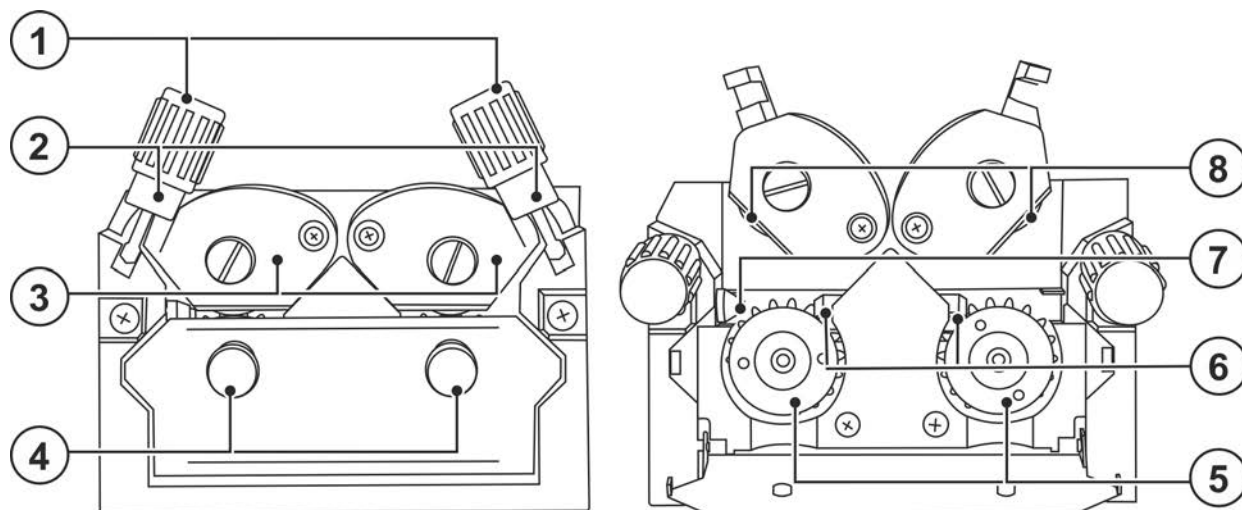

Figure 5-12

Item	Symbol	Description
1		Adjusting nut
2		Feed roll tensioner Fixing the clamping unit and setting the pressure.
3		Clamping unit
4		Knurled screw
5		Drive roller
6		Guide tube
7		Wire feed nipple
8		Pressure roller

- Extend and lay out the torch hose package.
- Unfasten pressure units and fold out (clamping units and pressure rollers will automatically flip upwards).
- Unwind welding wire carefully from the wire spool and insert through the wire inlet nipple over the drive roller grooves and the guide pipe into the capillary tube and Teflon core using guide pipe.
- Press the clamping element with the pressure roller back downwards and fold the wire units back up again (wire electrode should be in the groove on the drive roller).
- Set the contact pressure with the adjusting nuts of the pressure unit.
- Press the wire inching button until the wire electrode projects out of the welding torch.

5.2.2.4 Spool brake setting

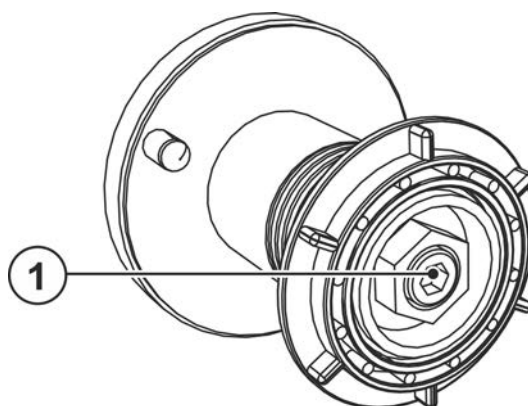

Figure 5-13

Item	Symbol	Description
1		Allen screw Securing the wire spool retainer and adjustment of the spool brake

- Tighten the Allen screw (8 mm) in the clockwise direction to increase the braking effect.

Tighten the spool brake until the wire spool no longer turns when the wire feed motor stops but without it jamming during operation!

5.2.3 Welding task selection

For selection of the welding task and for general operation see the relevant Control operating instructions.

5.3 MMA welding

5.3.1 Connecting the electrode holder and workpiece lead

⚠ CAUTION



Risk of crushing and burns!

When changing stick electrodes there is a risk of crushing and burns!

- Wear appropriate and dry protective gloves.
- Use an insulated pair of tongs to remove the used stick electrode or to move welded workpieces.

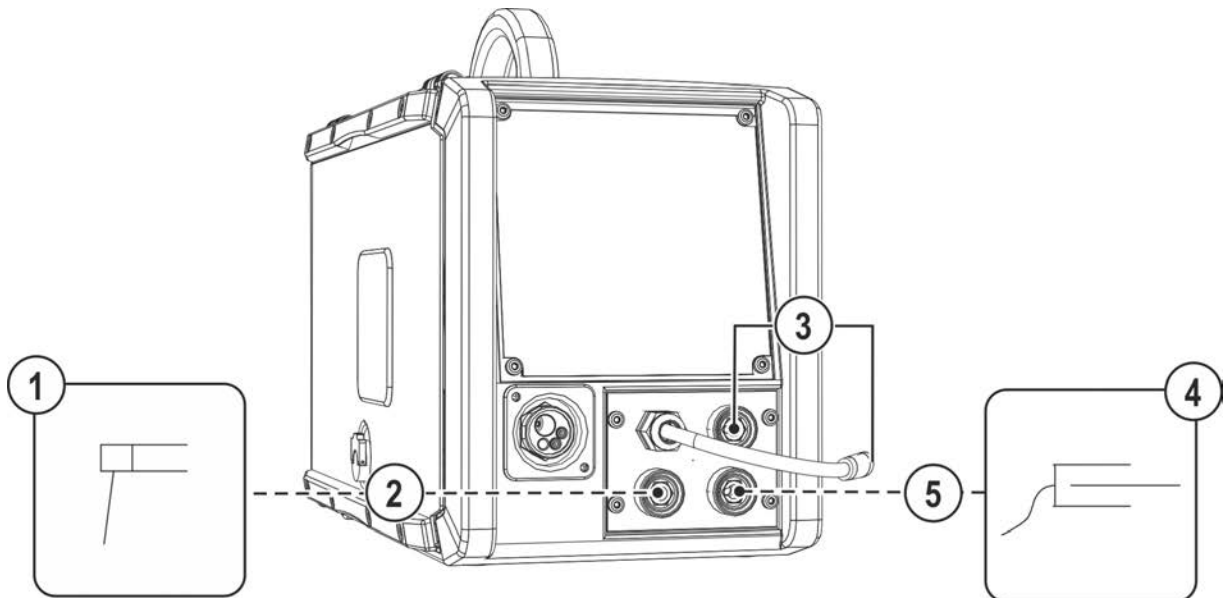

Figure 5-14

Item	Symbol	Description
1		Electrode holder
2		Connection socket for (+) welding current Electrode holder or workpiece lead connection
3		Polarity selector plug welding current cable • Connect to the park socket.
4		Workpiece
5		Connection socket, “-” welding current Electrode holder or workpiece lead connection

- Insert the polarity selection plug in the park socket and lock in place by turning to the right.
- Insert the electrode holder plug and workpiece lead into the welding current socket depending on application and lock in place by turning to the right. The corresponding polarity will be based on the information of the electrode manufacturer on the electrode packaging.

5.3.2 Welding task selection

For selection of the welding task and for general operation see the relevant Control operating instructions.

5.4 TIG welding

5.4.1 Preparing the TIG welding torch

The TIG welding torch is to be equipped to suit the relevant welding task!

- Fit suitable tungsten electrodes and
- an appropriate shielding gas nozzle.
- Observe the operating instructions for the TIG welding torch!

5.4.2 Welding torch and workpiece line connection

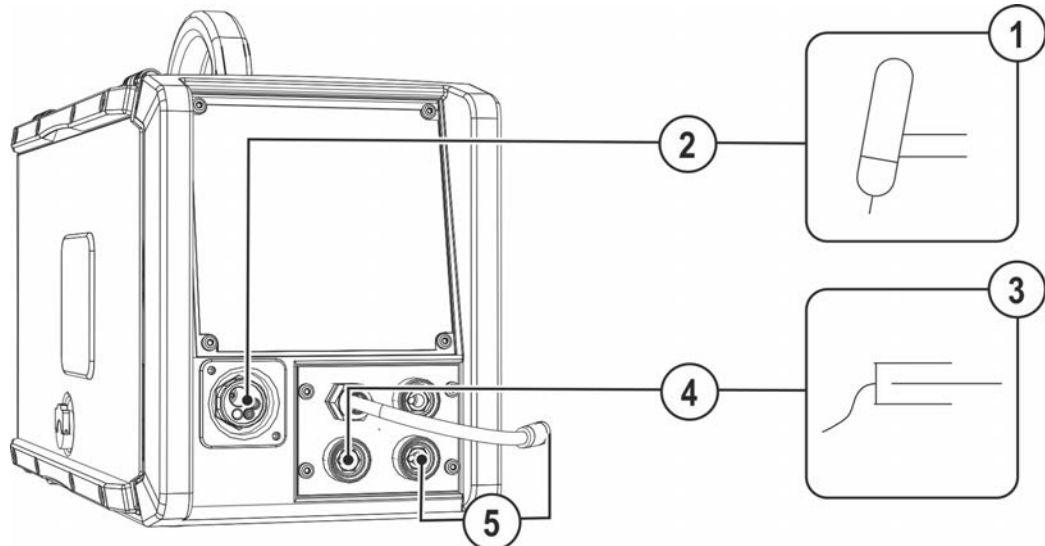

Figure 5-15

Item	Symbol	Description
1		Welding torch
2		Welding torch connection - Euro torch connector Welding current, shielding gas and torch trigger integrated
3		Workpiece
4		Connection socket (+) welding current • TIG welding: Workpiece connection
5		Polarity selector plug welding current cable Internal welding current cable for central connection/welding torch. • Connection socket for (-) welding current

- Insert the central plug for the welding torch into the central connector and screw together with crown nut.
- Insert the polarity selection plug into the "-" welding current connection socket and lock in place by turning to the right.
- Insert the plug of the workpiece lead into the "+" welding current connection socket and lock in place by turning to the right.

5.4.3 Welding task selection

For selection of the welding task and for general operation see the relevant Control operating instructions.

6 Maintenance, care and disposal

6.1 General

⚠ DANGER

Risk of injury due to electrical voltage after switching off!
Working on an open machine can lead to fatal injuries!
Capacitors are loaded with electrical voltage during operation. Voltage remains present for up to four minutes after the mains plug is removed.

1. Switch off machine.
2. Remove the mains plug.
3. Wait for at last 4 minutes until the capacitors have discharged!

⚠ WARNING

Improper maintenance, testing and repairs!
Maintenance, testing and repair of the machine may only be carried out by skilled and qualified personnel (authorised service personnel). A competent person is someone who, based on training, knowledge and experience, can recognize the hazards and possible consequential damage that may occur when testing power sources and can take the necessary safety precautions.

- Follow the maintenance instructions > see 6.3 chapter.
- If any of the test requirements below are not met, the unit must not be put back into operation until it has been repaired and tested again.

Repair and maintenance work may only be performed by qualified authorised personnel; otherwise the right to claim under warranty is void. In all service matters, always consult the dealer who supplied the machine. Return deliveries of defective equipment subject to warranty may only be made through your dealer. When replacing parts, use only original spare parts. When ordering spare parts, please quote the machine type, serial number and item number of the machine, as well as the type designation and item number of the spare part.

Under the specified ambient conditions and normal working conditions this machine is essentially maintenance-free and requires just a minimum of care.

Contamination of the machine may impair service life and duty cycle. The cleaning intervals depend on the ambient conditions and the resulting contamination of the machine. The minimum interval is every six months.

6.2 Explanation of icons

Personnel

	Welder / operator		Qualified person (authorised service personnel)
--	-------------------	--	---

Test

	Visual inspection		Functional test
--	-------------------	--	-----------------

Period, interval

	One-shift operation		Multi-shift operation
	Every 8 hours		Daily
	Weekly		Monthly
	Every 6 months		Annually

6.3 Maintenance schedule

Inspector	Type of inspection	8h	24h	Maintenance step	Repairer
				<p>! Only personnel designated as inspectors or repairers due to their training are allowed to carry out the relevant work step! Non-applicable inspection points are omitted.</p>	
				<ul style="list-style-type: none"> Check and clean the welding torch. Deposits in the welding torch may cause short circuits, impair the welding result and lead to welding torch damage! Check wire drive, welding torches, and liner elements for application-related equipment and setting. Clean the wire feed rolls on a regular basis (depending on the degree of soiling). Replace worn wire feed rolls. Connections of the welding current leads (check for tight and locked seating). Is shielding gas cylinder with gas cylinder securing elements (chain/belt) secured? Strain relief: Are hose packages secured with strain relief? 	
				<ul style="list-style-type: none"> Checking all supply lines and their connections (pipes, hoses, hose packages) for damage or leaks. Checking the welding system for damage to the housing. Transport elements (strap, lifting eyes, handle, wheels, parking brake) corresponding safety elements (if necessary fuse caps) are present and flawless? 	
				<ul style="list-style-type: none"> Cleaning connections of coolant pipes (quick connect coupling, connections) from impurities and install protective caps when not in use. Gas test that the solenoid valve opens and closes properly. Checking operating, signalling and indicator lights, protective devices and actuators. 	
				<ul style="list-style-type: none"> Check wire feed roll holder (wire feed rolls must be firmly seated on their holders and must not have any play) Cleaning dirt filter (if applicable) 	
				<ul style="list-style-type: none"> Checking correct mounting of the wire spool. 	
				<ul style="list-style-type: none"> Clean external surfaces with a damp cloth (do not use aggressive cleaning agents). 	
				<ul style="list-style-type: none"> Cleaning the power source (inverter) 	
				<ul style="list-style-type: none"> Cleaning heat exchanger (torch cooling) 	
				<ul style="list-style-type: none"> Coolant change (torch cooling) 	
				<ul style="list-style-type: none"> Periodic inspection and testing 	
				<ul style="list-style-type: none"> The coolant must be checked using the appropriate frost protection tester TYP 1 (KF) or FSP (blueCool) for sufficient frost protection and replaced if necessary (accessories). 	

6.4 Disposing of equipment



Proper disposal!

The machine contains valuable raw materials, which should be recycled, and electronic components, which must be disposed of.

- Do not dispose of in household waste!
- Observe the local regulations regarding disposal!

In addition to the national or international regulations mentioned below, it is mandatory to follow the respective national laws and regulations on disposal.

- According to European provisions (Directive 2012/19/EU on Waste of Electrical and Electronic Equipment), used electric and electronic equipment may no longer be placed in unsorted municipal waste. It must be collected separately. The symbol depicting a waste container on wheels indicates that the equipment must be collected separately.

This machine has to be disposed of, or recycled, in accordance with the waste separation systems in use.

According to German law (law governing the distribution, taking back and environmentally correct disposal of electrical and electronic equipment (ElektroG)), used machines are to be placed in a collection system separate from unsorted municipal waste. The public waste management utilities (communities) have created collection points at which used equipment from private households can be disposed of free of charge.

The deletion of personal data is the responsibility of the end user.

Lamps, batteries or accumulators must be removed and disposed of separately before disposing of the device. The type of battery or accumulator and its composition is marked on the top (type CR2032 or SR44). The following EWM products may contain batteries or accumulators:

- Welding helmets
Batteries or accumulators are easy to remove from the LED cassette.
- Device controls
Batteries or accumulators are located on the back of these in corresponding sockets on the circuit board and are easy to remove. The controls can be removed using standard tools.

Information on returning used equipment or collections can be obtained from the respective municipal administration office. Devices can also be returned to EWM sales partners across Europe.

Further information on the topic of the disposal of electrical and electronic equipment can be found on our website at: <https://www.ewm-group.com/de/nachhaltigkeit.html>.

7 Rectifying faults

All products are subject to rigorous production checks and final checks. If, despite this, something fails to work at any time, please check the product using the following flowchart. If none of the fault rectification procedures described leads to the correct functioning of the product, please inform your authorised dealer.

7.1 Software version of the machine control

The query of the software versions only serves to inform the authorised service staff. It is available in the machine configuration menu.

7.2 Error messages (power source)

Depending on the options of the machine display, a fault is shown as follows:

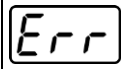
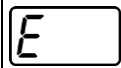
Display type - machine control	Display
Graphic display	
two 7-segment displays	
one 7-segment display	

The possible cause of the fault is signalled by a corresponding fault number (see table). In the case of an error, the power unit shuts down.

The possible error numbers displayed depend on the machine series and version!

- Document machine errors and inform service staff as necessary.
- If multiple errors occur, these are displayed in succession.

Error message	Possible cause	Remedy
E 0	Start signal set in the event of errors	Do not press the torch trigger or the foot-operated remote control
E 4	Temperature error	Allow the machine to cool down
E 5	Mains overvoltage	Switch off the machine and check the mains voltage
E 6	Mains undervoltage	
E 7	Electronics error	Switch the machine off and on again. If the error persists, notify service department
E 9	Secondary overvoltage	
E12	Voltage reduction error (VRD)	
E13	Electronics error	
E14	Alignment error in current recording	Switch off the machine, place the electrode holder in an insulated position and switch the machine back on. If the error persists, notify service department
E15	Error in one of the electronics supply voltages	Switch the machine off and on again. If the error persists, notify service department
E23	Temperature error	Allow the machine to cool down
E32	Electronics error	Switch the machine off and on again. If the error persists, notify service department
E33	Alignment error in voltage recording	Switch off the machine, place the electrode holder in an insulated position and switch the machine back on. If the error persists, notify service department

Error message	Possible cause	Remedy
E34	Electronics error	Switch the machine off and on again. If the error persists, notify service department
E37	Temperature error	Allow the machine to cool down
E40	Motor fault	Check wire feed mechanism, switch the machine off and on again, inform the service department if the fault persists.
E51	Earth fault (PE error)	Connection between welding wire and machine casing
E55	Failure of a mains phase	Switch off the machine and check the mains voltage
E58	Short circuit in welding circuit	Switch off the machine and check welding current leads for correct installation, e.g. by placing the electrode holder in an insulated position; detach current lead from degaussing.

7.3 Checklist for rectifying faults

The correct machine equipment for the material and process gas in use is a fundamental requirement for perfect operation!

Legend	Symbol	Description
	↗	Fault/Cause
	✘	Remedy

Collective interference signal light illuminates

- ↗ Excess temperature, welding machine
 - ✘ Allow the machine to cool down whilst still switched on
- ↗ Welding current monitoring device triggered (stray welding currents flowing across the protective earth). The error must be reset by switching the machine off and on again.
 - ✘ Welding wire is touching electrically conductive casing parts (check wire guide, has the welding wire sprung off the wire spool?).
 - ✘ Check for a correct mounting of the welding lead. Fit the feeder clamp of the welding lead as close as possible to the arc.

Excess temperature signal light illuminates

- ↗ Excess temperature, welding machine
 - ✘ Allow the machine to cool down whilst still switched on

Functional errors

- ✓ Mains fuse triggers - unsuitable mains fuse
 - ✘ Set up recommended mains fuse > see 8 chapter.
- ✓ Machine does not start up after switching on (device fan and possibly coolant pump have no function).
 - ✘ Connect the control cable of the wire feeder.
- ✓ All machine control signal lights are illuminated after switching on
- ✓ No machine control signal light is illuminated after switching on
- ✓ No welding power
 - ✘ Phase failure > check mains connection (fuses)
- ✓ Machine restarts continuously
- ✓ Wire feeder without function
- ✓ System does not start up
 - ✘ Make control lead connections and check that they are fitted correctly.
- ✓ Loose welding current connections
 - ✘ Tighten power connections on the torch and/or on the workpiece
 - ✘ Properly fasten the contact tip and contact tip holder.

Wire feed problems

- ✓ Contact tip blocked
 - ✘ Clean and, if necessary, replace.
- ✓ Setting the spool brake > see 5.2.2.4 chapter
 - ✘ Check settings and correct if necessary
- ✓ Setting pressure units > see 5.2.2.3 chapter
 - ✘ Check settings and correct if necessary
- ✓ Worn wire rolls
 - ✘ Check and replace if necessary
- ✓ Kinked hose packages
 - ✘ Extend and lay out the torch hose package
- ✓ Wire guide core or spiral is dirty or worn
 - ✘ Clean core or spiral; replace kinked or worn cores

7.4 Dynamic power adjustment

This requires use of the appropriate mains fuse.

Observe mains fuse specification > see 8 chapter!

The dynamic power adjustment automatically adjusts the welding performance to an uncritical level for the fuse.

The dynamic power adjustment can be set in two increments in the machine configuration menu using parameter "FUS": 20 A, 16 A.

The currently selected value will be shown on the "cal" section of the display for three seconds after the machine has been switched on.

7.5 Resetting welding parameters to the factory settings

All customised welding parameters that are stored will be replaced by the factory settings.

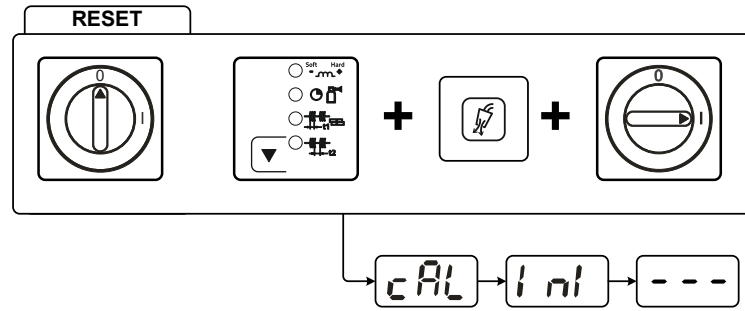





Figure 7-1

Display	Setting/selection
	Calibration The machine will be calibrated for approx 2 seconds each time it is switched on.
	Initialising Keep the push-button pressed until is shown on the display.

8 Technical data

8.1 Picomig 220

Performance specifications and guarantee only in connection with original spare and replacement parts!

	MIG/MAG	TIG	MMA
Welding current I ₂	5 A to 220 A	5 A to 230 A	5 A to 180 A
Welding voltage according to standard U ₂	14,3 V to 25,0 V	10,2 V to 19,2 V	20,2 V to 27,2 V
Duty cycle DC at 40°C/104°F ^[1]	220 A (30 %) 170 A (60 %) 150 A (100 %)	230 A (35 %) 200 A (60 %) 170 A (100 %)	180 A (35 %) 150 A (60 %) 130 A (100 %)
Open circuit voltage U ₀	70 V		
Mains voltage (Tolerance)	1 x 230 V (-40 % to +15 %)		
Frequency	50/60 Hz		
mains fuse ^[2]	1 x 16 A		
Mains connection cable	H07RN-F3G2,5		
max. Connected load S ₁	6,5 kVA	5,2 kVA	5,8 kVA
Recommended generator power	8,8 kVA	7 kVA	7,8 kVA
Power consumption P _i	15 W		
Cos φ / efficiency	0,99 / 86 %		
Protection class / Overvoltage category	I / III		
Contamination level	3		
Insulation class / protection classification	H / IP 23		
Residual current circuit breaker	Type B (recommended)		
Noise level ^[3]	<70 dB(A)		
Ambient temperature	-25 °C to +40 °C / -13 °F to 104 °F		
Machine cooling / Torch cooling	Fan (AF) / gas		
Wire feed speed	1 m/min to 18 m/min / 39.37 ipm to 708.66 ipm		
Factory-installed roll equipment	0,8/1,0 mm for steel wire		
Drive	4 rollers (37 mm)		
Wire spool diameter	Standardised wire spools up to 200 mm		
Welding torch connection	Euro torch connector		
Workpiece lead (min.)	25 mm ²		
EMC class	A		
Test mark	 /  /  / 		
Standards used	See declaration of conformity (appliance documents)		
Dimensions (l x b x h)	559 x 276 x 340 mm / 22.0 x 10.9 x 13.4 inch		
Weight	18,0 kg / 39.7 lb		

^[1] Load cycle: 10 min. (60 % DC \triangleq 6 min. welding, 4 min. pause) AC power sources: 50 Hz - waveform = square.

^[2] Safety fuses are recommended DIAZED xxA gG. When using automatic cutouts, the "C" trigger characteristic must be used.

^[3] Noise level during idle mode and operation under standard load according to IEC 60974-1 at the maximum operating point.

9 Accessories

Performance-dependent accessories like torches, workpiece leads, electrode holders or intermediate hose packages are available from your authorised dealer.

9.1 Transport system

Type	Designation	Item no.
Trolley 35-1	Transport vehicle	090-008629-00000
ON Trolley Picomig	Trolley Picomig 180 with holder for 300 mm wire spool	092-000312-00000
Type	Designation	Item no.
Trolley 54	Transport vehicle	090-008639-00000
ON TA TR.21	Cross arm for holding a welding machine or wire feeder	092-004390-00000
ON WAK D.09/D.12/T.05	Wheel assembly kit	092-002550-00000

9.2 Shielding gas supply (shielding gas cylinder for welding machine)

Type	Designation	Item no.
Proreg Ar/CO2 230bar 15l D	Pressure regulator with manometer	394-008488-10015
Proreg Ar/CO2 230bar 30l D	Pressure regulator with manometer	394-008488-10030
DM 842 Ar/CO2 230bar 15l D	Pressure regulator with manometer	394-002910-00015
DM 842 Ar/CO2 230bar 30l D	Pressure regulator with manometer	394-002910-00030
GH 2X1/4" 2M	Gas hose	094-000010-00001
GH 2x1/4" 3m	Gas hose	094-000010-00003
GH 2X1/4" 5m	Gas hose	094-000010-00005
GH 2X1/4" 10 m	Gas hose	094-000010-00011
GH 2X1/4" 15m	Gas hose	094-000010-00015

9.3 Option for retrofitting

Type	Designation	Item no.
ON Filter T.0005	Retrofit option, dirt filter for air inlet	092-002553-00000
ON CS T.005/TG.0003/D.0002	Crane suspension for Picomig 180 / 185 D3 / 305 D3, Phoenix and Taurus 355 compact, drive 4	092-002549-00000
ON Trolley Picomig	Trolley Picomig 180 with holder for 300 mm wire spool	092-000312-00000
ON WAK D.09/D.12/T.05	Wheel assembly kit	092-002550-00000

9.4 General accessories

Type	Designation	Item no.
SKGS 16A 250V CEE7/7, DIN 49440/441	Protective contact plug, solid rubber	094-001756-00000
ADAP CEE16/SCHUKO	Earth contact coupling/CEE16A plug	092-000812-00000
ADAP DZA/EZA	Adapter for welding torches with Dinse connector to Euro torch connector on the machine	094-016765-00000
DSP	Sharpener for liner	094-010427-00000
Cutter	Hose cutter	094-016585-00000
CAPTUB L=69 mm; Ø ≤ 1,6 mm	Capillary tube	094-014667-00000
GuideTube L=66 mm, Ø 4,4 x 5 mm	Guide tube	094-018316-00000

10 Replaceable parts



The manufacturer's warranty becomes void if non-genuine parts are used!

- *Only use system components and options (power sources, welding torches, electrode holders, remote controls, spare parts and replacement parts, etc.) from our range of products!*
- *Only insert and lock accessory components into the relevant connection socket when the machine is switched off.*

10.1 Wire feed rollers

10.1.1 Wire feed rollers for steel wire

Type	Designation	Item no.
FE 2DR4R 0,6+0,8	Drive rollers, 37 mm, steel	092-000839-00000
FE 2DR4R 0,8+1,0	Drive rollers, 37 mm, steel	092-000840-00000
FE 2DR4R 0,9+1,2	Drive rollers, 37 mm, steel	092-000841-00000
FE 2DR4R 1,0+1,2	Drive rollers, 37 mm, steel	092-000842-00000
FE 2DR4R 1,2+1,6	Drive rollers, 37 mm, steel	092-000843-00000
FE/AL 2GR4R SF	Pressure rollers, smooth, 37 mm	092-000414-00000

10.1.2 Wire feed rollers for aluminium wire

Type	Designation	Item no.
AL 4ZR4R 0,8+1,0	Twin rollers, 37 mm, for aluminium	092-000869-00000
AL 4ZR4R 1,0+1,2	Twin rollers, 37 mm, for aluminium	092-000848-00000
AL 4ZR4R 1,2+1,6	Twin rollers, 37 mm, for aluminium	092-000849-00000
AL 4ZR4R 2,4+3,2	Twin rollers, 37 mm, for aluminium	092-000870-00000

10.1.3 Wire feed rollers for cored wire



Type	Designation	Item no.
ROE 2DR4R 0,8/0,9+0,8/0,9	Drive rollers, 37 mm, cored wire	092-000834-00000
ROE 2DR4R 1,0/1,2+1,4/1,6	Drive rollers, 37 mm, cored wire	092-000835-00000
ROE 2DR4R 1,4/1,6+2,0/2,4	Drive rollers, 37 mm, cored wire	092-000836-00000
ROE 2DR4R 2,8+3,2	Drive rollers, 37 mm, cored wire	092-000837-00000
ROE 2GR4R	Pressure rollers, knurled, 37mm	092-000838-00000

10.1.4 Conversion kit

Type	Designation	Item no.
URUE VERZ>UNVERZ FE/AL 4R SF	Conversion kit, 37mm, 4-roller drive on non-toothed rollers (steel/aluminium)	092-000415-00000
URUE ROE 2DR4R 0,8/0,9+0,8/0,9 SF	Conversion kit, 37 mm, 4-roller drive for cored wire	092-000410-00000
URUE ROE 2DR4R 1,0/1,2+1,4/1,6 SF	Conversion kit, 37 mm, 4-roller drive for cored wire	092-000411-00000
URUE ROE 2DR4R 1,4/1,6+2,0/2,4 SF	Conversion kit, 37 mm, 4-roller drive for cored wire	092-000412-00000
URUE ROE 2DR4R 2,8+3,2 SF	Conversion kit, 37 mm, 4-roller drive for cored wire	092-000413-00000
URUE AL 4ZR4R 0,8+1,0 SF	Conversion kit, 37 mm, 4-roller drive for aluminium	092-002268-00000
URUE AL 4ZR4R 1,0+1,2 SF	Conversion kit, 37 mm, 4-roller drive for aluminium	092-002266-00000
URUE AL 4ZR4R 1,2+1,6 SF	Conversion kit, 37 mm, 4-roller drive for aluminium	092-002269-00000
URUE AL 4ZR4R 2,4+3,2 SF	Conversion kit, 37 mm, 4-roller drive for aluminium	092-002270-00000

11 Appendix

11.1 Average wire electrode usage

5 m/min – 197 ipm								
	mm				inch			
	1.0	1.2	1.6		.040	.045	.060	
Steel	1.8	2.7	4.7	kg/h	3.9	5.9	10.3	lb/h
Stainless steel	1.9	2.8	4.8		4.1	6.1	10.5	
Aluminium	0.6	0.9	1.6		1.3	1.9	3.5	
10 m/min – 394 ipm								
Steel	3.7	5.3	9.5	kg/h	8.1	11.6	20.9	lb/h
Stainless steel	3.8	5.4	9.6		8.3	11.9	21.1	
Aluminium	1.3	1.8	3.2		2.8	3.9	7.0	

11.2 Average shielding gas usage

11.2.1 MIG/MAG welding

	mm	1.0	1.2	1.6	2.0
	inch	.040	.045	.060	.080
l/min		10	12	16	20
gal/min		2.64	3.17	4.22	5.28

11.2.2 TIG welding

	Gas nozzle number	4	5	6	7	8	10
	∅ mm	6.5	8.0	9.5	11	12.5	16
	∅ inch	0.26	0.31	0.37	0.43	0.5	0.63
l/min		6	8	10	12		15
gal/min		1.58	2.11	2.64	3.17		3.96

11.3 Searching for a dealer

Sales & service partners
www.ewm-group.com/en/specialist-dealers



"More than 400 EWM sales partners worldwide"